

# BENECOR



## BENECOR DEF CENTRIFUGAL PUMP

Benecor's Centrifugal Pumps are specifically designed and engineered for pumping DEF. Strong delivery pressure makes it ideal for use in supplying DEF from storage tanks. This self-priming pump also has excellent suction capacity even when there are air bubbles in the liquid.

### Features:

- Self-Priming
- Excellent suction capacity
- Stainless Steel
- Built-in thermal and current overload protection

### Technical Specifications:

- Dual Voltage 115v/230v 60Hz
- Liquid quality requirements: clean, free from solid or abrasive substances
- Liquid temperature range: from +32° F to +113° F
- Maximum ambient temperature: +104° F
- Maximum operating pressure: 8 bar (116 PSI)
- Installation: fixed in a horizontal position
- Motor protection level: NEMA 4 (IP44)
- Terminal box protection: NEMA 4X (IP55)

N.	DESCRIPTIONS*	MATERIALS
1	PUMP BODY	STAINLESS STEEL AISI 304 X5 CrNi 1810 UNI 6900/71
4	IMPELLER	TECHNOPOLYMER A
7	SHAFT WITH ROTOR	STAINLESS STEEL AISI 303 X10 CrNiS 1809 UNI 6900/71
16	MECHANICAL SEAL	CARBON/CERAMIC
28	OR GASKET	VITON
36	SEAL COVER	STAINLESS STEEL AISI 304 X5 CrNi 1810 UNI 6900/71
160	NOZZLE-VENTURI-DIFFUSER ASSEMBLY	TECHNOPOLYMER A

\* In contact with the liquid

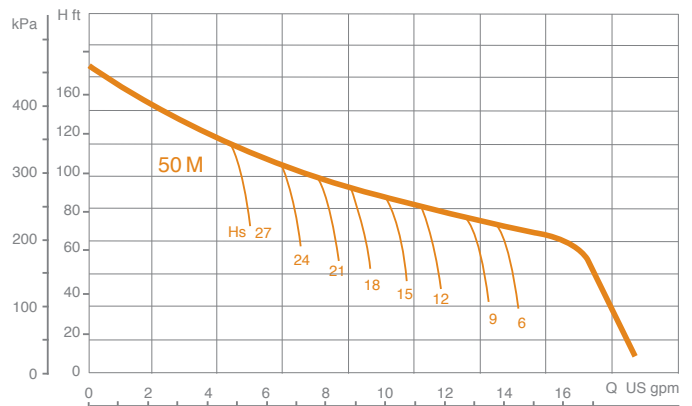
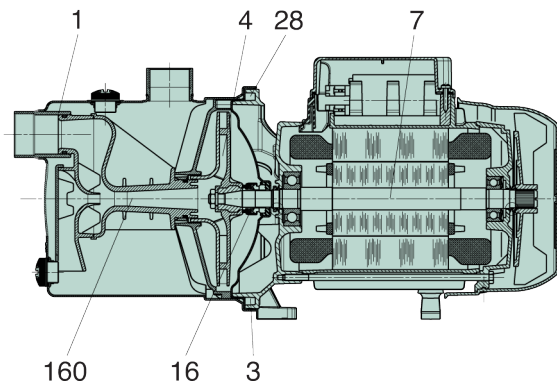

Contact Benecor Customer Service  
For Product & Pricing Information At:  
**248.437.4437**

